

Lugano Soap Pump

Installation Guide

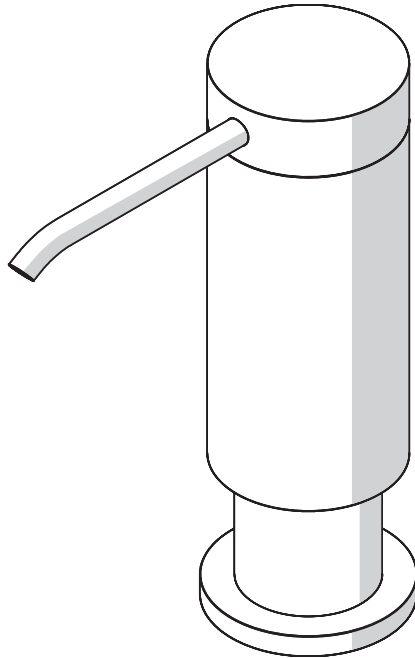

P A R
TAPS



www.paptaps.com



[/ParTapsPtyLtd](https://www.facebook.com/ParTapsPtyLtd)



[@par_taps](https://www.instagram.com/par_taps)

Important Information

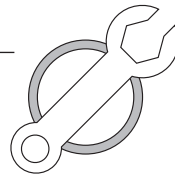

Before Installation

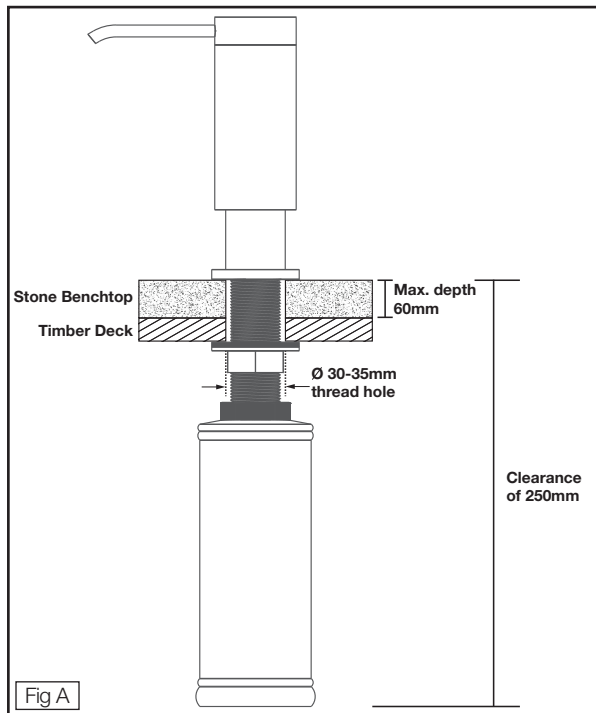

Prior to installing, calculate the finished benchtop thickness to ensure the Flange and Soap Pump Assembly will fit the final assembly.

Drill a 30mm (no larger than 35mm) hole in the timber deck and stone / benchtop surface.

A maximum of 60mm benchtop thickness to allow cover flange to fit soap pump assembly.

Ensure a clearance of 250mm from the top of the stone benchtop surface

Recommended clearances indicated Fig A.

Soap Pump

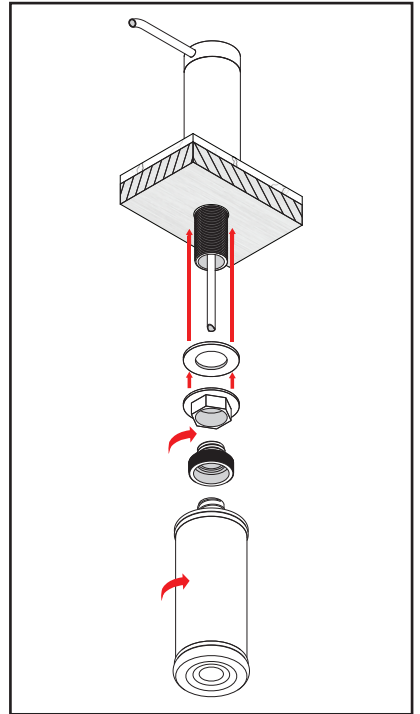
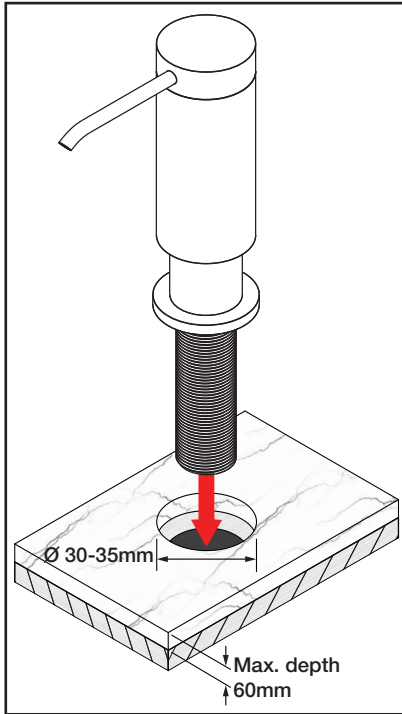
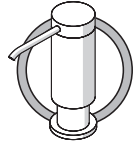

1. Insert soap pump assembly into the cutout benchtop.
Please note: The flange should be on during this step, to clear benchtop depth, slide the flange up.

2. Slide the rubber washer up on the timber deck. Then secure the washer with the screw lock.
Then screw in the lid and bottle



P A R
TAPS